



# Olympic Games 2008

(CHN Beijing, 9-15 August 2008)

## -60 kg

33 Judoka

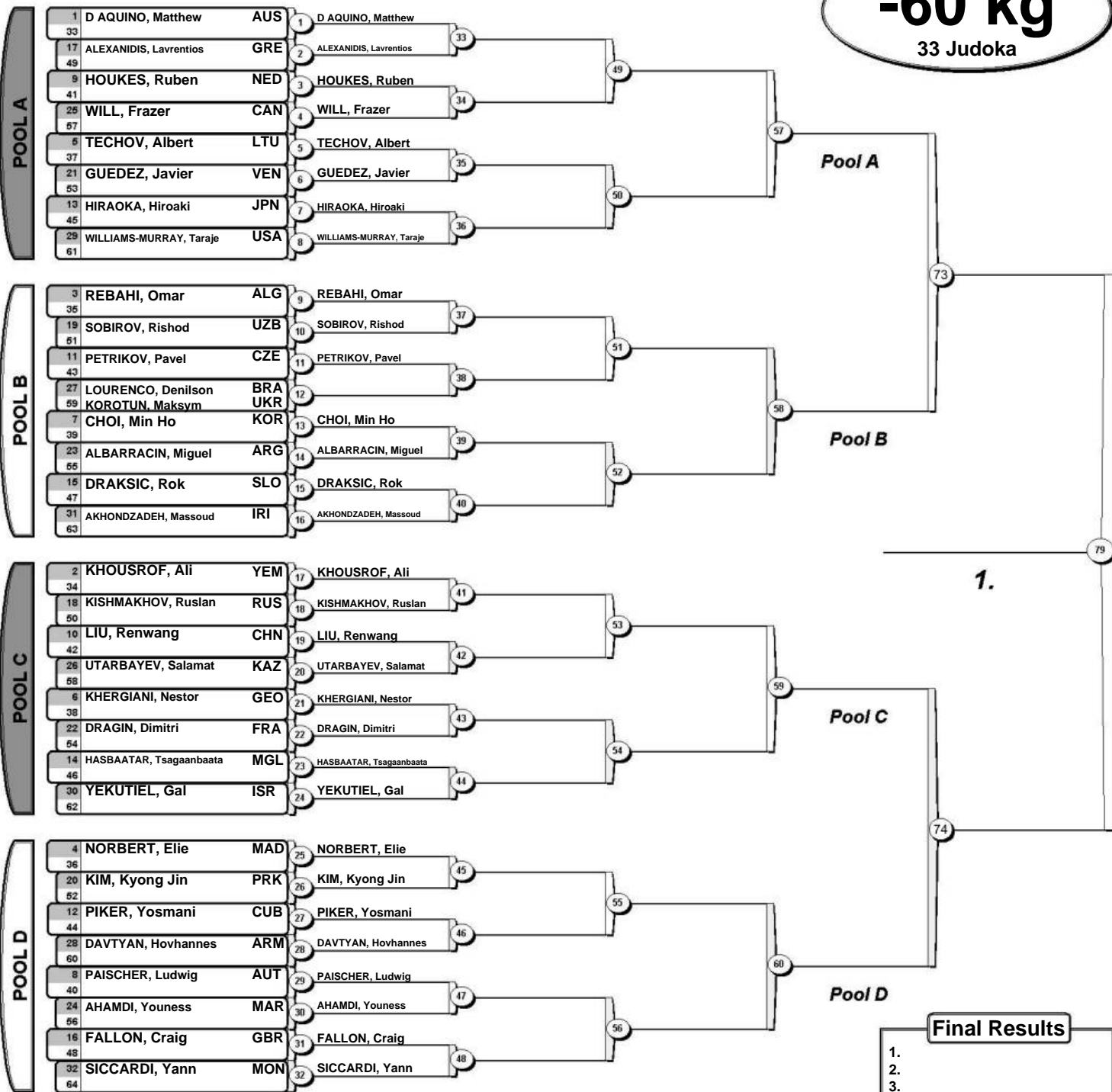

### Repechage

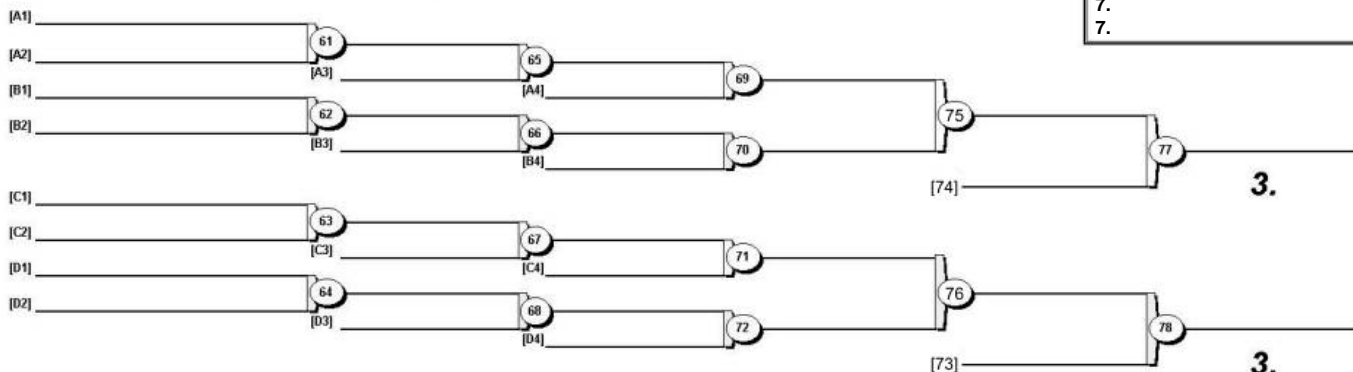



# Olympic Games 2008

(CHN Beijing, 9-15 August 2008)

## -66 kg

33 Judoka

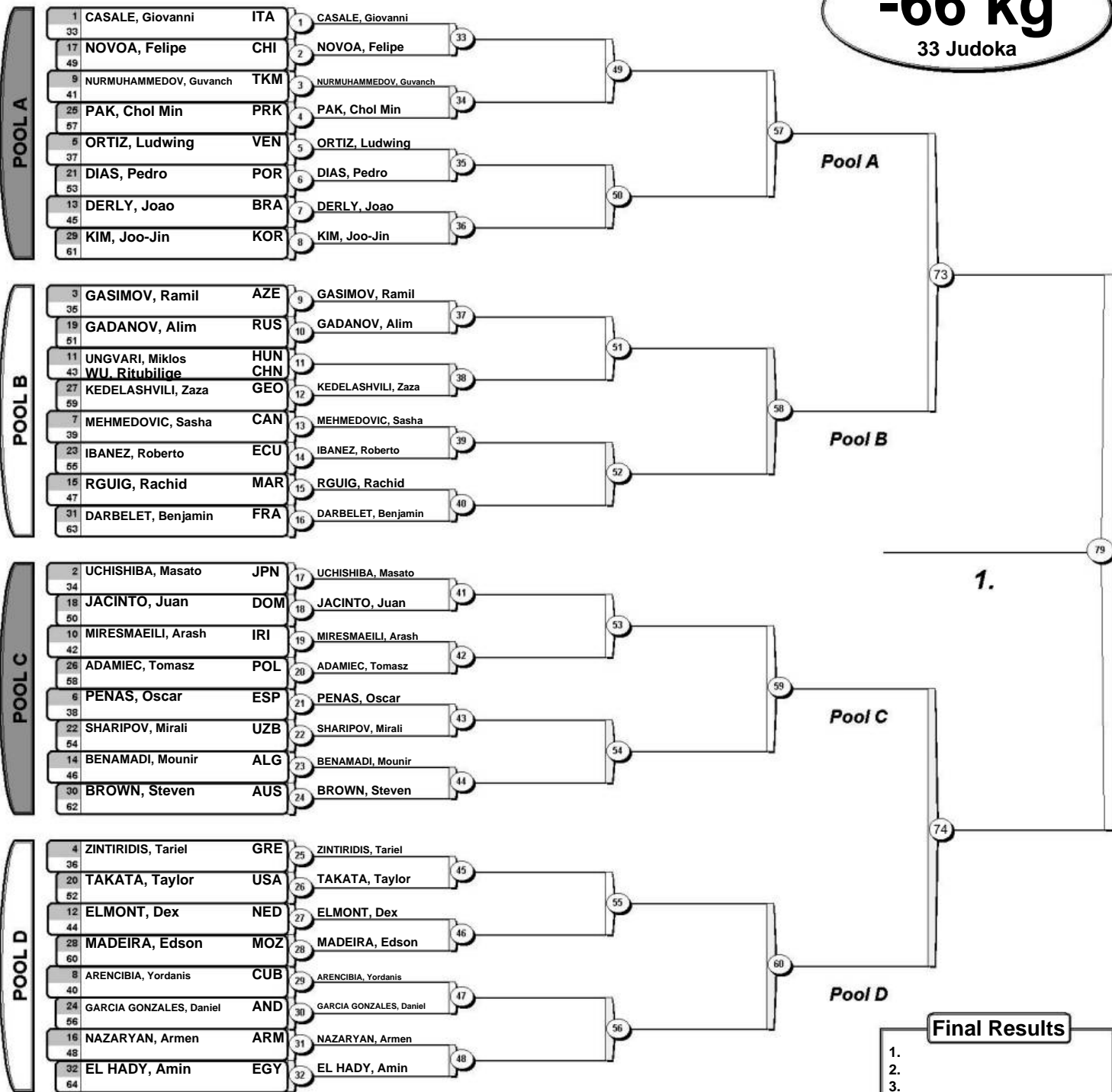

### Repechage

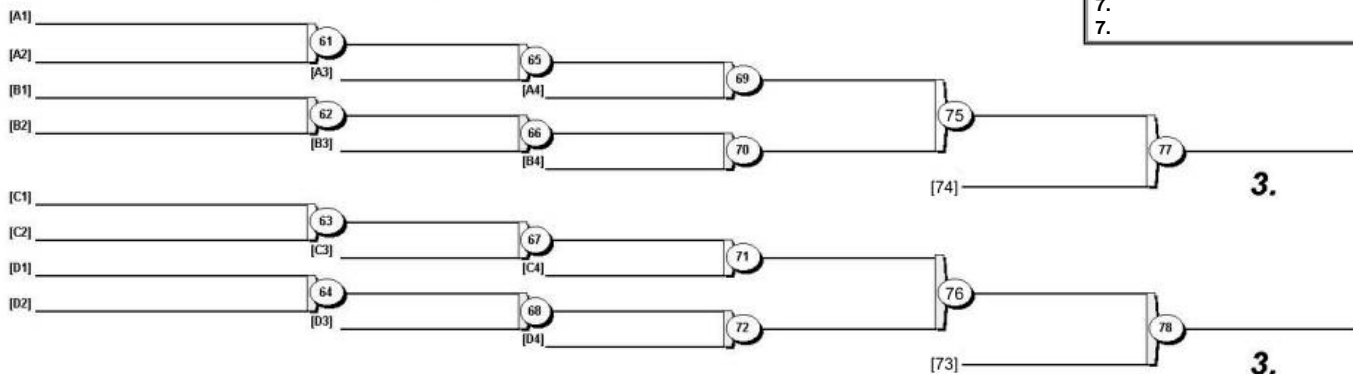



# Olympic Games 2008

(CHN Beijing, 9-15 August 2008)

## -73 kg

32 Judoka

POOL A

1	TRITTON, Nicholas	CAN	1
17	PINA, Joao	POR	17

9	KANAMARU, Yusuke	JPN	2
25	MALOMAT, Ali	IRI	25

5	WILKOMIRSKI, Krzysztof	POL	3
21	ZELJONIJ, Vsevolod	LAT	18

13	RESER, Ryan	USA	4
29	GANTUMUR, Dasdavaa	MGL	29

POOL B

3	KEVKHISHVILI, David	GEO	5
19	TOMA, Sergiu	MDA	19

11	GIRONES, Ronald	CUB	6
27	KIM, Chol Su	PRK	27

7	MERIDJA, Amar	ALG	7
23	SEMENOV, Konstantin	BLR	20

15	MAMMADLI, Einur	AZE	8
31	VAN TICHELDT, Dirk	BEL	31

POOL C

2	BOQUIEV, Rasul	TJK	9
18	KIBANZA, Lundoloki	COD	18

10	BILODID, Gennadiy	UKR	10
26	MEZHIDOV, Salamu	RUS	26

6	IVERSON, Dennis	AUS	11
22	HUYSUZ, Sezer	TUR	22

14	SI, Rijigawa	CHN	12
30	LEON, Richard	VEN	30

POOL D

4	JEZEK, Jaromir	CZE	13
20	MUMINOV, Shokir	UZB	20

12	WANG, Ki Chun	KOR	14
28	IBRAGIMOV, Rinat	KAZ	28

8	ALQUBAISI, Saeed Rashed	UAE	15
24	AUGUST, Marlon	RSA	24

16	BERTOLOTTI, Mariano	ARG	16
32	GUILHEIRO, Leandro	BRA	32

Pool A - Winner  
Vainqueur / Sieger

Pool B - Winner  
Vainqueur / Sieger

Pool C - Winner  
Vainqueur / Sieger

Pool D - Winner  
Vainqueur / Sieger

1.

Results  
Résultat / Platzierungen

- 1.
- 2.
- 3.
- 3.
- 5.
- 7.
- 7.

Repechage / Trostrunde

[A1]			
[A2]		29	33
		[A3]	

[B1]			
[B2]		30	34
		[B3]	

[C1]			
[C2]		31	35
		[C3]	

[D1]			
[D2]		32	36
		[D3]	

[38]

[37]

3.

3.



# Olympic Games 2008

(CHN Beijing, 9-15 August 2008)

## -81 kg

35 Judoka

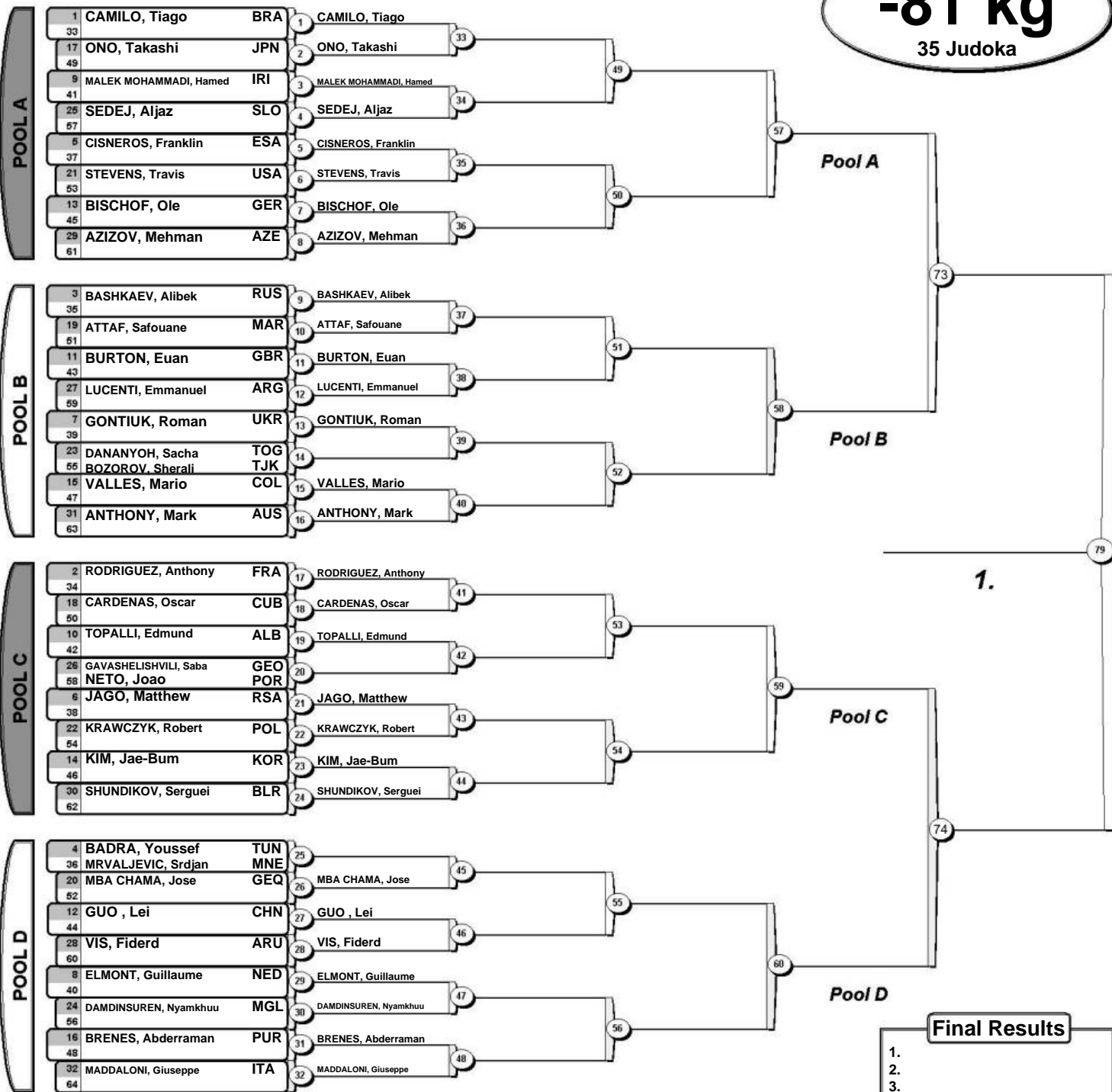

1.

Final Results

- 1.
- 2.
- 3.
- 3.
- 5.
- 5.
- 7.
- 7.

### Repechage

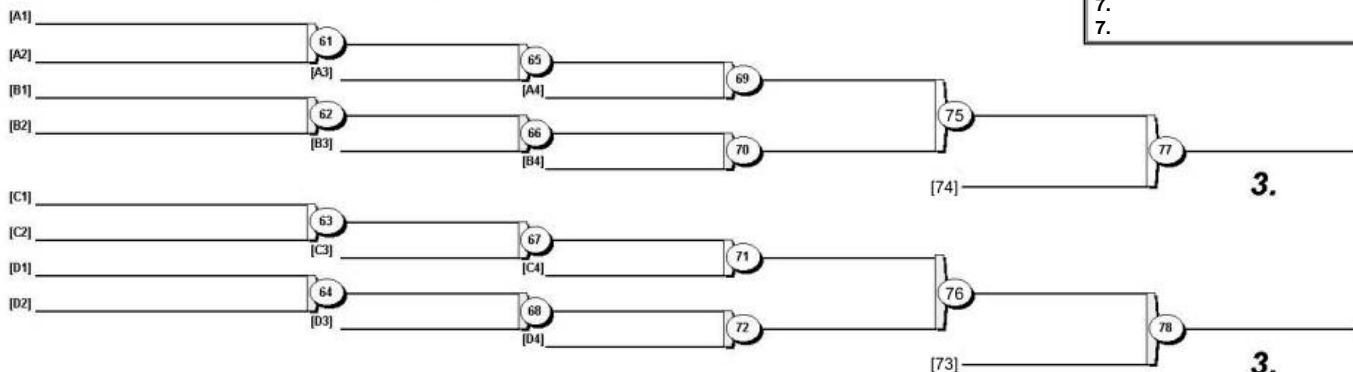

3.

3.



# Olympic Games 2008

(CHN Beijing, 9-15 August 2008)

## -90 kg

31 Judoka

POOL A

1 CHOI, Sun-Ho KOR  
17 MESBAH, Hesham EGY

1

2

TSIREKIDZE, Irakli

9 TSIREKIDZE, Irakli GEO  
25

5 MAMMADOV, Elkhan AZE  
21 ASRANQULOV, Negmatullo TJK

3

4

13 GORDON, Winston GBR  
29 NABIEV, Khurshid UZB

POOL B

3 KELLY, Daniel AUS  
19 IZUMI, Hiroshi JPN

5

6

11 KAZUSIONAK, Andrei BLR  
27 GHOMI, Hossein IRI

7 PERSHIN, Ivan RUS  
23 TREZISE, Patrick RSA

7

8

15 ROSATTI, Diego ARG  
31 OLSON, Brian USA

POOL C

2 SANTOS, Eduardo BRA  
18 HE, Yanzhu CHN

9

10

10 CAMACHO, Jose VEN  
26 GREKOV, Valentyn UKR

6 MELONI, Roberto ITA  
22 BORODAVKO, Jevgenij LAT

11

12

14 DAFREVILLE, Yves-Matthieu FRA  
30 GONZALES, Asley CUB

POOL D

4 EL ASSRI, Mohamed MAR  
20 BENIKHLEF, Amar ALG

13

14

12 CHILECLANA, Alexis PUR  
28 ALARZA, David ESP

8 ILIADIS, Ilias GRE  
24 HUIZINGA, Mark NED

15

16

16 PINSKE, Michael GER  
32 ASCHWANDEN, Sergei SUI

Pool A - Winner  
Vainqueur / Sieger

Pool B - Winner  
Vainqueur / Sieger

Pool C - Winner  
Vainqueur / Sieger

Pool D - Winner  
Vainqueur / Sieger

1.

Results  
Résultat / Platzierungen

- 1.
- 2.
- 3.
- 3.
- 5.
- 7.
- 7.

Repechage / Trostrunde

[A1]

[A2]

29

[A3]

30

[B3]

[B1]

[B2]

31

[C3]

[C1]

[C2]

[D1]

[D2]

31

[C3]

32

[D3]

32

[D3]

36

33

34

35

36

35

40

37

39

41

42

[38]

[37]

3.

3.



# Olympic Games 2008

(CHN Beijing, 9-15 August 2008)

## -100 kg

32 Judoka

POOL A

1	CORREA, Luciano	BRA	1
17	GROL, Henk	NED	17
9	DEMONTFAUCON, Frédéric	FRA	2
25	ZEEVI, Ariel	ISR	25
5	COSTA, Eduardo	ARG	3
21	PÁLKOVÁCS, Zoltan	SVK	18
13	SHAO, Ning	CHN	4
29	MATYASZEK, Przemyslaw	POL	29

Pool A - Winner  
Vainqueur / Sieger

POOL B

3	MARTINEZ, Arturo	MEX	5
19	MOUSSIMA EWAN, Franck	CMR	19
11	HADFI, Daniel	HUN	6
27	BENSALEH, Mohamed Ali	LBA	26
7	MEKIC, Amel	BIH	7
23	VOLMAR, Adler	USA	20
15	ZHITKEYEV, Askhat	KAZ	8
31	ALENEZI, Talal	KUW	31

Pool B - Winner  
Vainqueur / Sieger

POOL C

2	COUSINS, Peter	GBR	9
18	ZHORZHOLIANI, Levan	GEO	18
10	MIRALIYEV, Movlud	AZE	10
26	AZZOUN, Hacene	ALG	26
6	MORGAN, Keith	CAN	11
22	DIEK, Teofilo	DOM	22
14	KURBANOV, Utkir	UZB	14
30	BRATA, Daniel	ROU	30

Pool C - Winner  
Vainqueur / Sieger

POOL D

4	GASYMOV, Ruslan	RUS	13
20	BEHRLA, Benjamin	GER	20
12	SUZUKI, Keiji	JPN	12
28	NAIDAN, Tuvshinbayar	MGL	14
8	ROSALES, Albenis	VEN	15
24	JANG, Sung-Ho	KOR	24
16	DESPAIGNE, Oreydis	CUB	16
32	CELOTTI, Matt	AUS	32

Pool D - Winner  
Vainqueur / Sieger

1.

Results  
Résultat / Platzierungen

- 1.
- 2.
- 3.
- 3.
- 5.
- 7.
- 7.

Repechage / Trostrunde

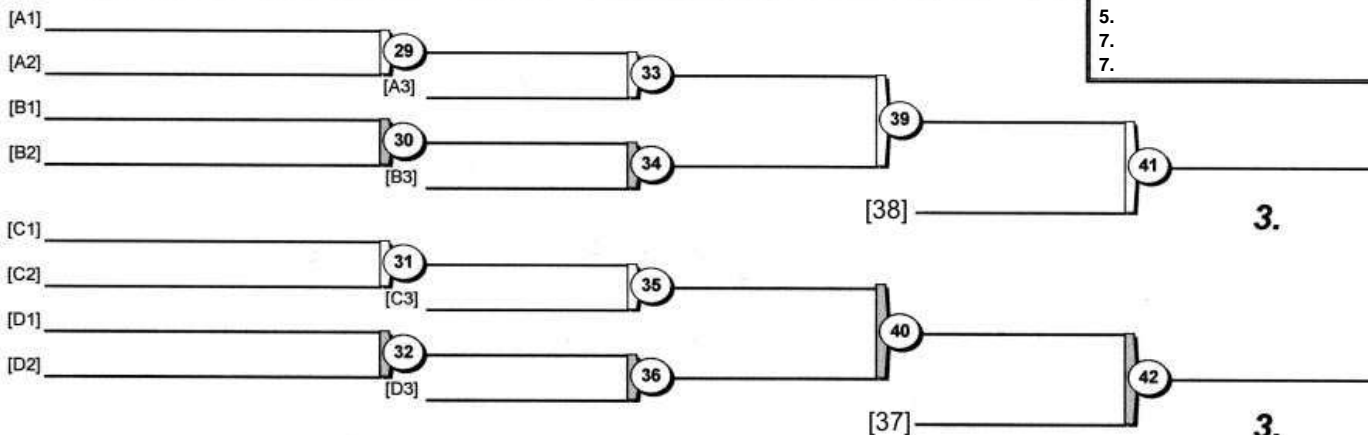

3.

3.



# Olympic Games 2008

(CHN Beijing, 9-15 August 2008)

## +100 kg

34 Judoka

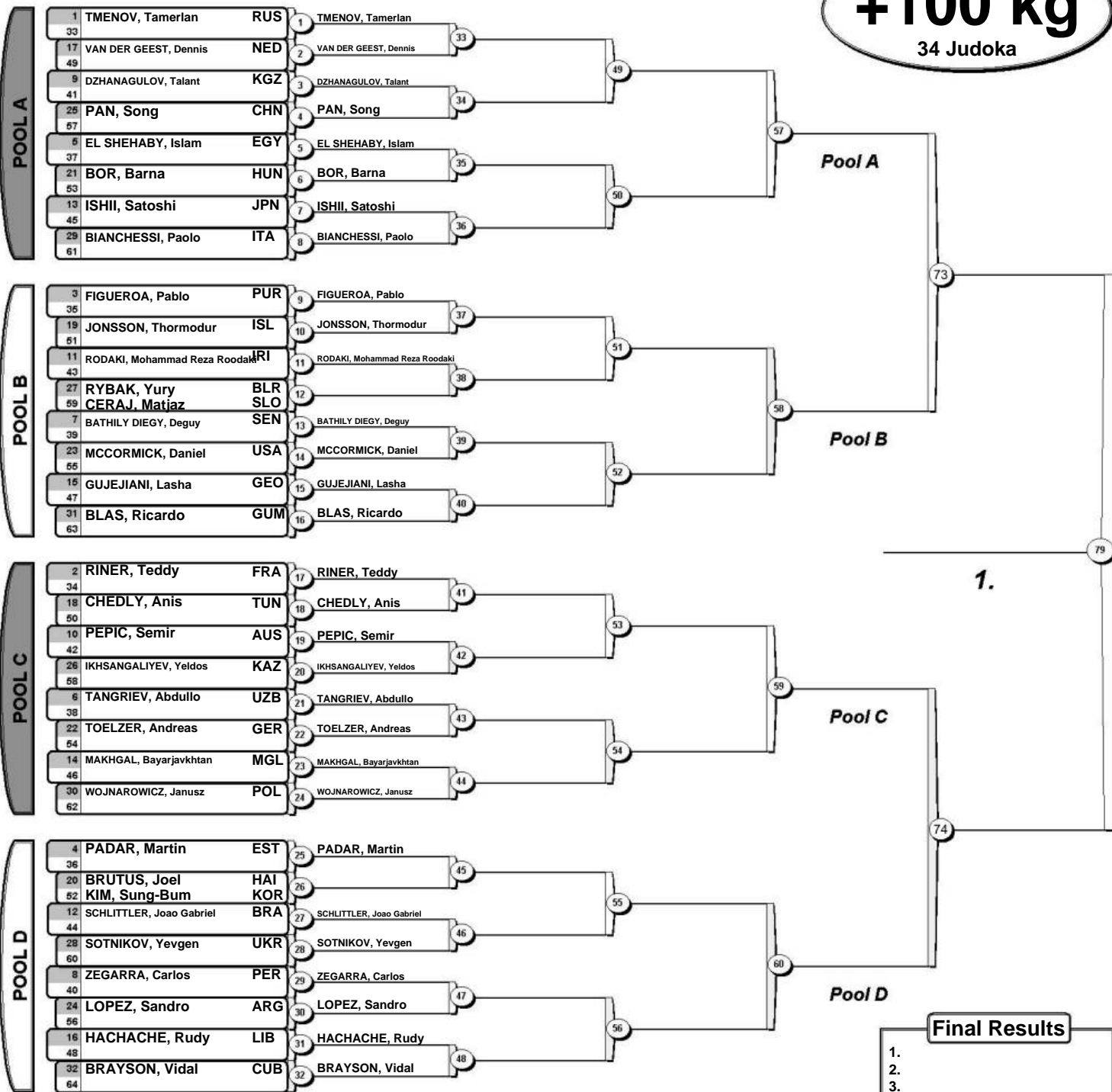

### Repechage

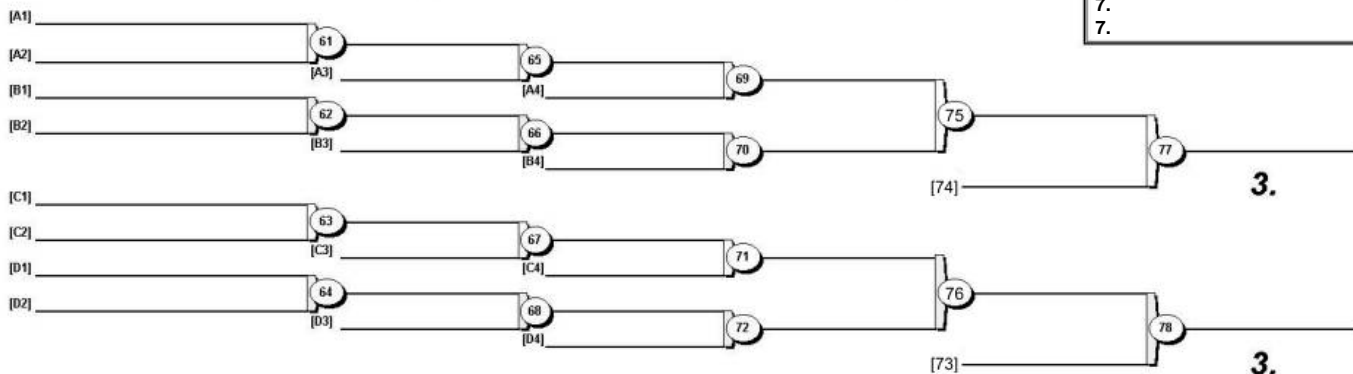



# Olympic Games 2008

(CHN Beijing, 9-15 August 2008)

## -48 kg

23 Judoka

POOL A

1	WU, Shugen	CHN	1	WU, Shugen
17			17	
9	TANI, Ryoko	JPN	2	
25	MATSUMOTO, Sayaka	USA	2	
5	PARETTO, Paula	ARG	3	PARETTO, Paula
21			18	
13	DAY, Tiffany	AUS	4	DAY, Tiffany
29			4	

Pool A - Winner  
Vainqueur / Sieger

POOL B

3	LUSNIKOVA, Lyudmyla	UKR	5	
19	MBARKI, Chahnez	TUN	5	
11	KIM, Young Ran	KOR	6	KIM, Young Ran
27			6	
7	CSERNOVICZKI, Eva	HUN	7	
23	MENEZES, Sarah	BRA	7	
15	DUMITRU, Alina	ROU	8	DUMITRU, Alina
31			8	

Pool B - Winner  
Vainqueur / Sieger

POOL C

2	KHUMUJAM, Devi	IND	9	
18	HORMIGO, Ana	POR	9	
10	PAK, Ok Song	PRK	10	PAK, Ok Song
26			10	
6	OUELOGO, Hanatou	BUR	11	OUELOGO, Hanatou
22			11	
14	JOSSINET, Frédérique	FRA	12	
30	NURGAZINA, Kelbet	KAZ	12	

Pool C - Winner  
Vainqueur / Sieger

POOL D

4	BASCHIN, Michaela	GER	13	BASCHIN, Michaela
20			13	
12	MOUSSA, Meriem	ALG	14	
28	ILENDU MBOUMBA, Sandrine	CAB	14	
8	BERMOY, Yanet	CUB	15	
24	MIRANDA, Glenda	ECU	15	
16	BOGDANOVA, Liudmila	RUS	16	BOGDANOVA, Liudmila
32			16	

Pool D - Winner  
Vainqueur / Sieger

1.

Results  
Résultat / Platzierungen

- 1.
- 2.
- 3.
- 3.
- 5.
- 7.
- 7.

Repechage / Trostrunde

[A1]		29		33			
[A2]			[A3]				
[B1]					39		
[B2]		30		34		41	
			[B3]				
[C1]					[38]		3.
[C2]		31		35			
[D1]			[C3]				
[D2]		32		36		40	
			[D3]				
					[37]		3.





# Olympic Games 2008

(CHN Beijing, 9-15 August 2008)

## -52 kg

22 Judoka

POOL A

1	VELAZQUEZ, Flor	VEN	1	VELAZQUEZ, Flor
17			17	
9	AN, Kum Ae	PRK	2	
25	MESTRE, Yagnelis	CUB	2	
5	SHIH, Pei-Chun	TPE	3	SHIH, Pei-Chun
21			18	
13	KALIYEVA, Sholpan	KAZ	4	KALIYEVA, Sholpan
29			4	

Pool A - Winner  
Vainqueur / Sieger

POOL B

3	HEYLEN, Ilse	BEL	5	
19	LA RIZZA, Audrey	FRA	5	
11	RYDER, Kristie-Anne	AUS	6	RYDER, Kristie-Anne
27			6	
7	DJURAEVA, Zinura	UZB	7	
23	TARANGUL, Romy	GER	7	
15	NAKAMURA, Misato	JPN	8	NAKAMURA, Misato
31			8	

Pool B - Winner  
Vainqueur / Sieger

POOL C

2	KHARITONOVA, Anna	RUS	9	KHARITONOVA, Anna
18			21	
10	MONTEIRO, Telma	POR	10	MONTEIRO, Telma
26			10	
6	CARRASCOSA, Ana	ESP	11	
22	MUNKHBAATAR, Bundmaa	MGL	11	
14	XIAN, Dongmei	CHN	12	XIAN, Dongmei
30			12	

Pool C - Winner  
Vainqueur / Sieger

POOL D

4	GARCIA, Maria	DOM	13	
20	FERNANDES, Andressa	BRA	13	
12	KIM, Kyung Ok	KOR	14	KIM, Kyung Ok
28			14	
8	DIEDHIOU, Hortanse	SEN	15	DIEDHIOU, Hortanse
24			15	
16	MULLER, Marie	LUX	16	
32	HADDAD, Soraya	ALG	16	

Pool D - Winner  
Vainqueur / Sieger

1.

Results  
Résultat / Platzierungen

- 1.
- 2.
- 3.
- 3.
- 5.
- 7.
- 7.

Repechage / Trostrunde

[A1]		29		33	
[A2]			[A3]		
[B1]					39
[B2]		30		34	
			[B3]		
[C1]					[38]
[C2]		31		35	
			[C3]		
[D1]					40
[D2]		32		36	
			[D3]		
					[37]

3.

3.



# Olympic Games 2008

(CHN Beijing, 9-15 August 2008)

## -57 kg

22 Judoka

POOL A

1 GOTAY, Valerie USA  
17 URALBAYEVA, Gulzat KAZ

1

17

9 FERNANDEZ, Isabel ESP  
25

2

FERNANDEZ, Isabel

25

5 KANG, Sin-Young KOR  
21 QUADROS, Ketleyn BRA

3

18

13 GRAVENSTIJN, Deborah NED  
29

4

GRAVENSTIJN, Deborah

18

Pool A - Winner  
Vainqueur / Sieger

POOL B

3 GASIMOVA, Kifayat AZE  
19

5

GASIMOVA, Kifayat

19

11 SATO, Aiko JPN  
27

6

SATO, Aiko

19

7 KOIVUMAKI, Nina FIN  
23

7

KOIVUMAKI, Nina

20

15 XU, Yan CHN  
31 LATROUS, Lila ALG

8

20

Pool B - Winner  
Vainqueur / Sieger

POOL C

2 QUINTAVALLE, Giulia ITA  
18 BOENISCH, Yvonne GER

9

21

10 KHISHIGBAT, Erdenet-Od MGL  
26

10

KHISHIGBAT, Erdenet-Od

26

6 HAREL, Barbara FRA  
22

11

HAREL, Barbara

22

14 KYE, Sun Hui PRK  
30 FILZMOSER, Sabrina AUT

12

22

Pool C - Winner  
Vainqueur / Sieger

POOL D

4 JLASSI, Nesrine TUN  
20

13

JLASSI, Nesrine

23

12 JEAN BAPTISTE, Ange Mercie HAI  
28 LUPETEY, Yurisleidis CUB

14

28

8 PEKLI, Maria AUS  
24

15

PEKLI, Maria

24

16 BACZKO, Bernadett HUN  
32

16

BACZKO, Bernadett

24

Pool D - Winner  
Vainqueur / Sieger

1.

Results  
Résultat / Platzierungen

- 1.
- 2.
- 3.
- 3.
- 5.
- 5.
- 7.
- 7.

Repechage / Trostrunde

[A1]

[A2]

29

[A3]

30

[B3]

[B1]

[B2]

30

[B3]

34

[38]

[C1]

[C2]

31

[C3]

35

[D1]

[D2]

32

[D3]

36

[37]

3.

3.



# Olympic Games 2008

(CHN Beijing, 9-15 August 2008)

## -63 kg

25 Judoka

POOL A

1 A ETONU, Silulu ASA  
17 VON HARNIER, Anna GER

1

2

3

4

9 TUMEN-OD, Battugs MGL  
25

2

3

4

5 DECOSSE, Lucie FRA  
21 ZOLNIR, Urska SLO

3

4

13 SCHLESINGER, Alice ISR  
29

4

5

POOL B

3 BEZZINA, Marcon MLT  
19 SAIDI, Kahina ALG

5

6

11 WILLEBOORDSE, Elisabeth NED  
27 KOVAL, Vera RUS

6

7

7 WON, Ok Im PRK  
23

7

8

15 KRUKOWER, Daniela ARG  
31 ARLOVE, Catherine AUS

8

POOL C

2 GONZALEZ, Driulis CUB  
18

9

10 CLARK, Sarah GBR  
26 HEILL, Claudia AUT

10

6 YLINEN, Johanna FIN  
22 WANG, Chin-Fang TPE

11

14 THAPA, Devu NEP  
30

12

POOL D

4 BARRETO, Ysis VEN  
20 HANE, Cecile SEN

13

12 TANIMOTO, Ayumi JPN  
28

14

8 BARBOSA, Danielli BRA  
24 KONG, Ja-Young KOR

15

16 XU, Yuhua CHN  
32

16

Repechage / Trostrunde

[A1]

[A2]

[B1]

[B2]

[C1]

[C2]

[D1]

[D2]

29

[A3]

30

[B3]

31

[C3]

32

[D3]

33

34

35

36

39

40

41

42

43

38

37

Pool A - Winner  
Vainqueur / Sieger

Pool B - Winner  
Vainqueur / Sieger

Pool C - Winner  
Vainqueur / Sieger

Pool D - Winner  
Vainqueur / Sieger

1.

Results  
Résultat / Platzierungen

- 1.
- 2.
- 3.
- 3.
- 5.
- 7.
- 7.

3.

3.



# Olympic Games 2008

(CHN Beijing, 9-15 August 2008)

## -70 kg

22 Judoka

POOL A

1	MESZAROS, Anett	HUN	1	MESZAROS, Anett
17			17	
9	KUZINA, Yulia	RUS	2	KUZINA, Yulia
25			25	
5	WANG, Juan	CHN	3	WANG, Juan
21			18	
13	PARK, Ka-Yeon	KOR	4	
29	UENO, Masae	JPN	4	

Pool A - Winner  
Vainqueur / Sieger

POOL B

3	OUERDANE, Rachida	ALG	5	OUERDANE, Rachida
19			19	
11	BOSCH, Edith	NED	6	
27	NAISIGAI, Sisilia	FIJ	6	
7	ROUSEY, Ronda	USA	7	
23	SURKIEVA, Nasiba	TKM	7	
15	PILOCIK, Katarzyna	POL	8	PILOCIK, Katarzyna
31			20	

Pool B - Winner  
Vainqueur / Sieger

POOL C

2	ALVEAR, Yuri	COL	9	
18	ZHANZUNOVA, Zhanar	KAZ	9	
10	HERNANDEZ, Anaysi	CUB	10	HERNANDEZ, Anaysi
26			21	
6	SCAPIN, Ylenia	ITA	11	SCAPIN, Ylenia
22			22	
14	JACQUES, Catherine	BEL	12	JACQUES, Catherine
30			22	

Pool C - Winner  
Vainqueur / Sieger

POOL D

4	SILVA, Mayra	BRA	13	
20	IGLESIAS, Leire	ESP	13	
12	EMANE, Gévrise	FRA	14	EMANE, Gévrise
28			23	
8	MENDY, Gisèle	SEN	15	
24	BOEHM, Annett	GER	15	
16	SMAL, Nataliya	UKR	16	SMAL, Nataliya
32			24	

Pool D - Winner  
Vainqueur / Sieger

1.

Results  
Résultat / Platzierungen

- 1.
- 2.
- 3.
- 3.
- 5.
- 5.
- 7.
- 7.

Repechage / Trostrunde

[A1]						
[A2]		29		33		
[B1]			[A3]			
[B2]		30		34		39
[B3]			[B3]			
[C1]					[38]	
[C2]		31		35		
[D1]			[C3]			
[D2]		32		36		40
[D3]			[D3]			
					[37]	

3.

3.



# Olympic Games 2008

(CHN Beijing, 9-15 August 2008)

## -78 kg

21 Judoka

POOL A

1	GRANT, Stephanie	AUS	1	GRANT, Stephanie
17			17	
9	LEVESQUE, Marylise	CAN	2	LEVESQUE, Marylise
25			25	
5	PUREVJARGAL, Lkhamdegd	MGL	3	PUREVJARGAL, Lkhamdegd
21			18	
13	YANG, Xiuli	CHN	4	
29	PROSKURAKOVA, Elena	KGZ	4	

Pool A - Winner  
Vainqueur / Sieger

POOL B

3	MORICO, Lucia	ITA	5	MORICO, Lucia
19			19	
11	NAKAZAWA, Sae	JPN	6	NAKAZAWA, Sae
27			26	
7	SILVA, Edinanci	BRA	7	SILVA, Edinanci
23			20	
15	MOSKALYUK, Vera	RUS	8	
31	SAN MIGUEL, Esther	ESP	8	

Pool B - Winner  
Vainqueur / Sieger

POOL C

2	WOLLERT, Heide	GER	9	
18	PRYSHCHEPA, Maryna	UKR	9	
10	YUSUF, Vivian	NGR	10	YUSUF, Vivian
26			21	
6	ROGERS, Michelle	GBR	11	ROGERS, Michelle
22			22	
14	JEONG, Gyeong Mi	KOR	12	JEONG, Gyeong Mi
30			27	

Pool C - Winner  
Vainqueur / Sieger

POOL D

4	ABIKEYEVA, Sagat	KAZ	13	
20	CASTILLO, Yalennis	CUB	13	
12	DIVIYA	IND	14	DIVIYA
28			23	
8	MILED, Houda	TUN	15	MILED, Houda
24			24	
16	POSSAMAI, Stephanie	FRA	16	
32	BRICENO, Lorena	ARG	16	

Pool D - Winner  
Vainqueur / Sieger

1.

Results  
Résultat / Platzierungen

- 1.
- 2.
- 3.
- 3.
- 5.
- 7.
- 7.

Repechage / Trostrunde

[A1]									
[A2]		29		33					
[B1]			[A3]						
[B2]		30		34		39			
[B3]			[B3]					41	
[C1]						[38]			3.
[C2]		31		35					
[D1]			[C3]						
[D2]		32		36		40			
[D3]			[D3]					42	
						[37]			3.



# Olympic Games 2008

(CHN Beijing, 9-15 August 2008)

## +78 kg

21 Judoka

POOL A

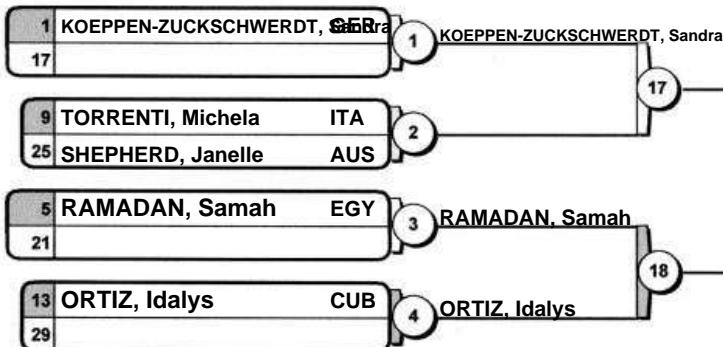

Pool A - Winner  
Vainqueur / Sieger

POOL B

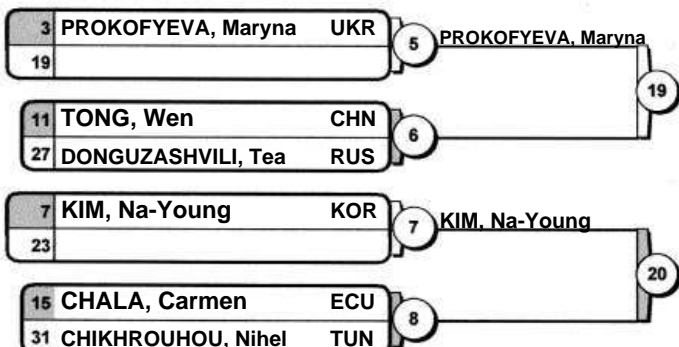

Pool B - Winner  
Vainqueur / Sieger

POOL C

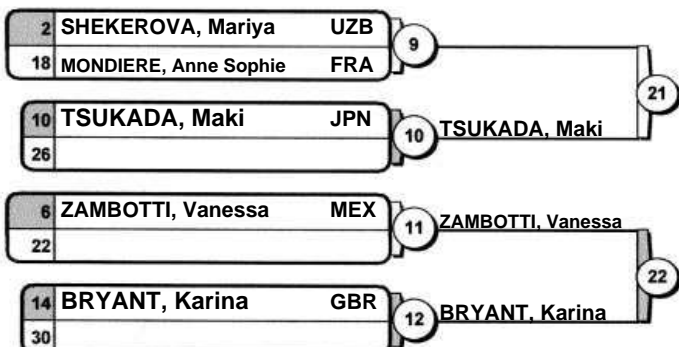

Pool C - Winner  
Vainqueur / Sieger

POOL D

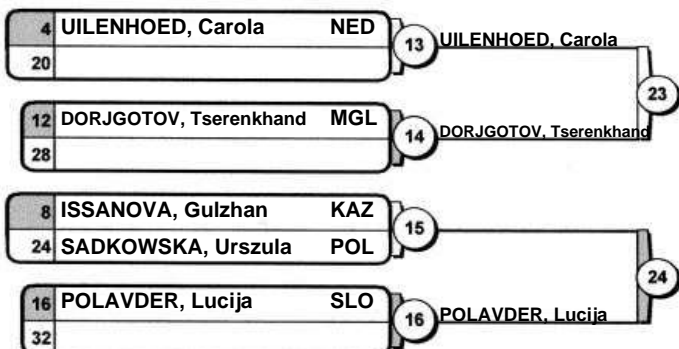

Pool D - Winner  
Vainqueur / Sieger

1.

Results  
Résultat / Platzierungen

- 1.
- 2.
- 3.
- 3.
- 5.
- 7.
- 7.

Repechage / Trostrunde

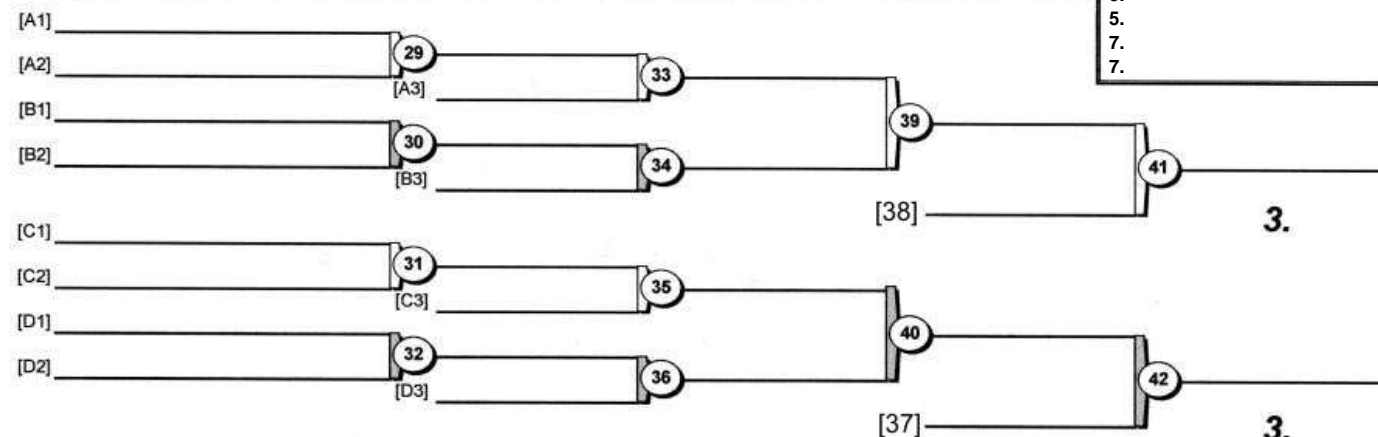

3.

3.